



CITY of NOVI CITY COUNCIL

**Agenda Item K
July 25, 2016**

SUBJECT: Approval to award bid for 55 hot water heaters at Meadowbrook Commons to Maza Construction Engineering in the amount of \$52,728.50.

SUBMITTING DEPARTMENT: Parks, Recreation and Cultural Services

CITY MANAGER APPROVAL: *[Signature]*

EXPENDITURE REQUIRED	\$ 52,728.50
AMOUNT BUDGETED	\$ 52,730.00
APPROPRIATION REQUIRED	\$ 0
LINE ITEM NUMBER	594-000.00-969.002

BACKGROUND INFORMATION: City Council approved the purchase of 55 hot water heaters at Meadowbrook Commons in the FY 2016-17 budget to replace the original units purchased in 2001. Units are being purchased in bulk in order to secure better contracting and material rates.

Eight (8) bids were received and opened on June 21, 2016, following a public bid solicitation period. Staff is recommending the award to Maza Construction Engineering, who was the lowest bidder. Maza met all of the requirements listed in the request for proposals.

A summary of the eight bids are as follows:

Contractor	Bid Price
Maza Construction Engineering	\$52,728.50
Allied Building Services	\$54,670.00
North Star Water Management	\$56,375.00
Optimum Contracting	\$57,750.00
Property Monkey	\$58,630.00
Rooter MD	\$60,335.00
Danboise Mechanical	\$64,625.00
D. Malone Mechanical	\$104,500.00

The replacement of hot water tanks is scheduled to begin in mid-summer and will be substantially complete by September.

RECOMMENDED ACTION: Approval to award bid for 55 hot water heaters at Meadowbrook Commons to Maza Construction Engineering in the amount of \$52,728.50.

	1	2	Y	N
Mayor Gatt				
Mayor Pro Tem Staudt				
Council Member Burke				
Council Member Casey				

	1	2	Y	N
Council Member Markham				
Council Member Mutch				
Council Member Wrobel				

CITY OF NOVI
Hot Water Heater Replacements - Meadowbrook Commons
June 14, 2016 2:00 P.M.

Company	Maza Construction Engineering	Allied Building Services	North Star Water Management	Optimum Contracting	Property Monkey	Rooter MD	Danboise Mechanical	D Malone Mechanical
A. Hot Water Heaters (Unit price installed)	\$ 900.00	\$ 884.00	\$ 900.00	\$ 1,050.00	\$ 930.00	\$ 1,031.00	\$ 1,065.00	\$ 1,900.00
Quantity	55	55	55	55	55	55	55	55
Hot water Heaters (Total)	\$ 49,500.00	\$ 48,620.00	\$ 49,500.00	\$ 57,750.00	\$ 51,150.00	\$ 56,705.00	\$ 58,575.00	\$ 104,500.00
B. Add Air vents (each)	\$ 58.70	\$ 110.00	\$ 125.00	included	\$ 136.00	\$ 66.00	\$ 110.00	included
Air Vents (Total)	\$ 3,228.50	\$ 6,050.00	\$ 6,875.00	\$ -	\$ 7,480.00	\$ 3,630.00	\$ 6,050.00	\$ -
TOTAL PRICE INSTALLED	\$ 52,728.50	\$ 54,670.00	\$ 56,375.00	\$ 57,750.00	\$ 58,630.00	\$ 60,335.00	\$ 64,625.00	\$ 104,500.00
Make/Model proposed	Lochinvar GTN04040	Rheem 40 gal/Oatey 22" water htr pan	Bradford White DRG240TGN	Lochinvar GTN0404	Bradford White RG240T6N	Bradford White RG240T6N	Lochinvar GTN04040	AO Smith GCR-40NG
Lead Time (ARO)	3 days based on volume	1-2 weeks	1-2 days upon NTP (heaters in stock)	14	2 weeks	2-3 days	2 weeks	14 days
Days require to complete the work	3 weeks	90	35 days	21	30 days	11-13 days	3 weeks	30 days
Addenda acknowledged	Yes	#2 only	Yes	Yes	Yes	Yes	Yes	#2 only
Accepts payment via P-Card	Yes	Yes	No	No	No	Yes	Yes	Yes
Service charges to use P-card	2%	blank				blank	N/A	2%
Exceptions/Comments	Maza Construction will not be responsible for removal and replacement of resident's possessions around the impacted area. We will need to be assisted in gaining access to the facility when staff is scheduled to conduct needed services.	Work to be performed during normal business hours. Dumpster may be utilized if customer allows & provides a staging area.			Property Monkey carries a 2 million dollar umbrella policy	If valve to water doesn't work, add \$65.00 to insall ProPress 3/4 ball valve.	6 yr warranty on water heaters does not include labor. This proposal excludes expansion tanks, mixing valves, and vacuum relief valves.	

MAZA Construction Engineering, Inc.

**15876 Schaefer HWY, Detroit, MI. 48227 E-mail: mazaconstruction@yahoo.com
www. Info @mazaconstruction.com , Phone: 734-223-9269**

June 21, 2016

City Clerk's Office
City of Novi
45175 Ten Mile Rd.
Novi, MI 48375-3024

ATTENTION: Ms. Sue Morianti, Purchasing Manager

Subject: Invitation to Bid-Hot Water Heater Replacements-Meadowbrook Commons

Honorable City Clerk:

Maza Construction Engineering Inc., is pleased to submit a response to the published Invitation to Bid entitled, Hot Water Heater Replacements- Meadowbrook Common. for a net sum of \$49,500.00. This response also acknowledged addendum 1 as well as 2 as per specifications for the installation of 8" x12" grill for a net sum of \$3,228.50 @ an installed price of \$58.70/unit .

We look forward to partnering with you in the quest to accomplish the requested services.

Thanks for the opportunity and attention.

Sincerely,

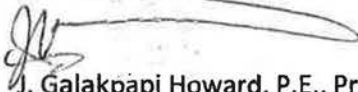

J. Galakpapi Howard, P.E., Project Manager
Maza Construction Engineering, Inc
Phone: 734-223-9269
E-mail: mazaconstruction@yahoo.com
Web: Info@mazaconstruction.com

Attached: Response to the Notice -City of Novi Invitation to Bid due 06/21/2016 @ 2 :00 PM



CITY OF NOVI

**HOT WATER HEATER REPLACEMENTS –
MEADOWBROOK COMMONS**

BID FORM

We, the undersigned as bidder, propose to furnish to the City of Novi, according to the specifications, terms, conditions and instructions attached hereto and made a part thereof:

A. HOT WATER HEATERS, as specified

Unit Price (Installed)		Quantity		Total Price (Installed)
\$900.00	X	55	=	\$49,500.00

Make/Models Proposed (please include cut sheets/specifications for the water heaters you will be providing)

Lochinvar /model GTN04040 (Please also see attached cut sheet/specifications)

Lead Time (after receipt of order) 3 days based on volume

Days required to complete the work 3 weeks

We acknowledge receipt of the following Addenda: 1 & 2
 (please indicate numbers)

We have included a completed W9 with our bid: Yes x No _____

Do you accept payment via Purchasing Card (credit card)? yes

Please indicate service charges to use Purchasing card, if any: 2%

EXCEPTIONS TO SPECIFICATIONS (all exceptions must be noted here):

Maza Construction Engineering Inc will not be responsible for the removal and replacement of "our" residents possessions around the impacted areas of the work.

COMMENTS: In response to Addendum # 2, The unit cost to install the requested 8" x12" transfer grill is \$58.70 with a total cost for all 55 units of \$3,228.50.

Coupled with the above Maza Construction Engineering, Inc will need to be assisted in gaining access to the facility when staff is scheduled to conduct needed services.

NON-IRAN LINKED BUSINESS

By signing below, I certify and agree on behalf of myself and the company submitting this proposal the following: (1) that I am duly authorized to legally bind the company submitting this proposal; and (2) that the company submitting this proposal is not an "Iran linked business," as that term is defined in Section 2(e) of the Iran Economic Sanctions Act, being Michigan Public Act No. 517 of 2012; and (3) That I and the company submitting this proposal will immediately comply with any further certifications or information submissions requested by the City in this regard.

THIS BID SUBMITTED BY:

Company (Legal Registration) MAZA CONSTRUCTION ENGINEERING, INC (licenses: P.E. 34301, 1st class stationary Engineer state license #330073; State Builder License 2101183422; Plumbing(State of Mich) license No. 8109954 State Mechanical license #7107071 & 7107166

Address 524 SPRINGFIELD DRIVE

City CANTON State MICHIGAN Zip 48188

Telephone 734-223-9269 Fax -----N/A-----

Representative's Name Mr. J. Galakpai Howard

Representative's Title Project Manager

Authorized Signature 

E-mail mazaconstruction@yahoo.com web: Info@mazaconstruction.com

Date 06-21-2016



CITY OF NOVI

**HOT WATER HEATER REPLACEMENTS –
MEADOWBROOK COMMONS**

ADDENDUM #2

INTENT: This addendum has been issued to modify and/or interpret the original specifications for the bid named above. Unless otherwise instructed, the information contained within this Addendum shall take precedence over anything contrary in the original specifications, and shall hereinafter be considered as part of the package.

RESPONSE: The Contractor shall verify receipt of this Addendum on the Bid Form.

CONTENTS: Included in this Addendum is one (1) page of written addenda description, plus 2 photos of area where air vents are to be installed.

CLARIFICATIONS:

- 1. The City's Plumbing Inspector is requiring an 8" x 12" air vent over the door of the laundry room to be done at the same time as the hot water heater replacements. This will require cutting a hole in the drywall in the laundry room and in the hallway and covering each side with a white return air vent cover. Available space above the door is 36" wide x 13" high. See photos. Please provide an "Add" price for each complete air vent installation in the Comments section on the bid form.**
- 2. The bid due date has been extended to Tuesday, June 21, 2016 at 2:00 p.m. The new deadline for questions is Tuesday, June 14, 2016 at 12:00 p.m.**

Sue Morianti
Purchasing Manager

Notice dated: June 13, 2016



Energy Saver Residential Gas Water Heaters

Energy Saver Gas Models

Lochinvar's Energy Saver residential gas models are available in 30, 40, and 50 gallon capacities in short and tall configurations.

Standard Features

- **Code Compliance** - The Energy Saver residential gas water heater meets the National Appliance Energy Conservation Act (NAECA) Energy Factor requirements effective April 16, 2015. Meets the thermal efficiency and standby loss requirements of ASHRAE/IES 90.1. Meets UBC, CEC and HUD national codes.
- **Flammable Vapor Ignition Resistant** - Combustion air is directed through a stainless steel flame arrestor plate specifically designed to prevent flame rollout and flammable vapor ignition. The design includes a safety thermal switch and protection from lint, dust and oil buildup.
- **Electronic Gas Control** - The gas valve features an internal microprocessor for precise temperature control, fast response and an LED status indicator for simplified service diagnostics. The valve is powered by a thermopile pilot requiring no external power source.
- **Low NOx Burner** - The patented radial burner design reduces NOx emissions by more than 33% delivering less than 40 ng/j of NOx.
- **Glass-Lined Steel Tank** - The durable glass lining is fused to the steel tank at 1600°F to assure lasting protection against rust and corrosion while providing clear, clean hot water. 300 PSI test pressure; 150 PSI working pressure.
- **Non-CFC Foam Insulation** - A uniform coverage of thick closed-cell foam insulation minimizes standby heat loss, maximizes heat retention and delivers a high Energy Factor.
- **Tank Saver Anode** - A large diameter, high capacity anode inhibits corrosion of the tank interior for long, trouble-free service.
- **Heat Trap** - Heat traps are built into the inlet and outlet connections to eliminate heat migration and heat loss in the water piping.
- **Temperature & Pressure Relief Valve** - Factory installed for optimum safety.
- **Brass Drain Valve** - An enhanced ball valve design for effective drainage and positive shut-off.
- **6-Year Limited Tank & Parts Warranty*** – See warranty sheet for details.
- **10-Year Extended Warranty Available** – Available for residential applications only.

*1-year limited tank & parts warranty when installed in a commercial application.



All models meet or exceed the NAECA and ASHRAE Energy Efficiency Standards

Dimensions and Specifications:

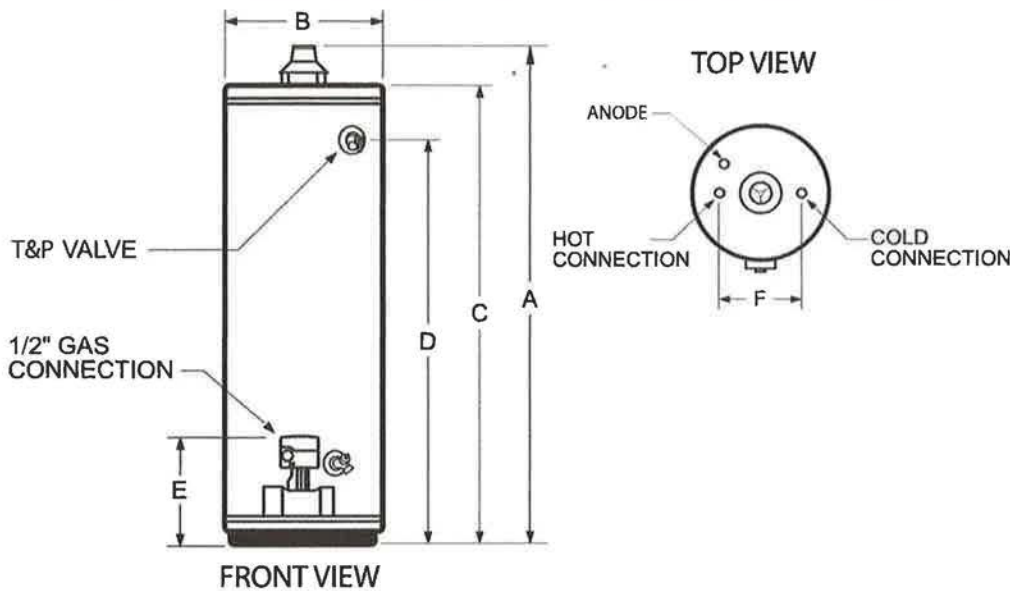

**FOR EASE IN ORDERING
BY MODEL NUMBER**

G S N 030 35

Residential Gas Short Natural Gas Gallon Capacity Input Rate

This is a short residential natural gas 30 gallon water heater with 35,500 Btu/Hr input rate.

Model Number	Nat. Gas		LP Gas		Energy Factor	1st Hr. Rating	GPH @ 90°F Rise	A	B	C	D	E	F	Gas Conn.	Water Conn.	Vent Size	Ship. Wt.
	Gal. Cap.	Btu/Hr Input	Btu/Hr Input	Btu/Hr Input													
Energy Saver with Insulation Blanket - Short Models																	
GSN030 35B	30	35,500	32,000	0.63	56	37	50"	18"	46-1/2"	40"	12"	8"	1/2"	3/4"	3" or 4"	110	
GSN040 40B	40	40,000	36,000	0.62	67	41	51-1/2"	20"	48"	41-1/4"	12"	8"	1/2"	3/4"	3" or 4"	134	
Energy Saver - Short Models																	
GSN030 35	30	35,500	32,000	0.63	62	37	50"	20"	46-1/2"	40"	12"	8"	1/2"	3/4"	3" or 4"	118	
GSN040 40	40	40,000	36,000	0.62	68	41	51-1/2"	22"	48"	41-1/4"	12"	8"	1/2"	3/4"	3" or 4"	135	
GSN050 40	50	40,000	40,000	0.60	93	43	53-1/4"	24"	49-3/4"	41-1/2"	12"	8"	1/2"	3/4"	3" or 4"	177	
Energy Saver with Insulation Blanket - Tall Models																	
GTN030 35B	30	35,500	32,000	0.63	64	37	61-1/2"	16"	58"	51-3/4"	12-1/4"	8"	1/2"	3/4"	3" or 4"	123	
GTN040 40B	40	40,000	36,000	0.62	70	42	61-3/4"	18"	58-1/4"	52"	12-1/4"	8"	1/2"	3/4"	3" or 4"	130	
GTN050 60B*	50	60,000	54,000	0.60	98	65	65-1/2"	22"	61"	54-1/4"	13-1/2"	8"	1/2"	3/4"	4"	190	
Energy Saver - Tall Models																	
GTN030 35	30	35,500	32,000	0.63	67	37	61-1/2"	18"	58"	51-3/4"	12-1/4"	8"	1/2"	3/4"	3" or 4"	132	
GTN040 35	40	35,500	N/A	0.62	67	38	61-3/4"	20"	58-1/4"	52"	12-1/4"	8"	1/2"	3/4"	3" or 4"	138	
GTN040 40*	40	40,000	36,000	0.62	70	42	61-3/4"	20"	58-1/4"	52"	12-1/4"	8"	1/2"	3/4"	3" or 4"	138	
GTN050 40*	50	40,000	37,000	0.60	88	41	60-3/4"	21"	57-1/4"	50-1/2"	12-1/4"	8"	1/2"	3/4"	3" or 4"	148	
GTN050 50*	50	50,000	45,000	0.60	92	54	60-3/4"	22"	57-1/4"	50-1/2"	12-1/4"	8"	1/2"	3/4"	4"	165	
GTN055 60*	55	60,000	54,000	0.59	103	65	59-3/4"	24"	55-1/4"	48"	13-1/2"	8"	1/2"	3/4"	4"	185	

Notes: In the model number, "N" indicates Natural gas; replace "N" with "L" to indicate L.P. gas models

* Optional Side Tappings are available on these models. Add "ST" to the end of the model number (Ex: GTN04040ST).

Certified for Potable Water and Space Heating Applications

This water heater is suitable for water heating and space heating. Toxic chemicals, such as those used for boiler water treatment shall NEVER be introduced into this system. This water heater may NEVER be connected to any existing heating system or components previously used with non-potable water heating appliances.



Lochinvar, LLC
300 Maddox Simpson Parkway
Lebanon, Tennessee 37090
P: 615.889.8900 / F: 615.547.1000
Lochinvar.com



Request for Taxpayer Identification Number and Certification

**Give Form to the
requester. Do not
send to the IRS.**

Print or type See Specific Instructions on page 2.	Name (as shown on your income tax return) MAZA CONSTRUCTION ENGINEERING, INC	
	Business name/disregarded entity name, if different from above	
	Check appropriate box for federal tax classification: <input type="checkbox"/> Individual/sole proprietor <input checked="" type="checkbox"/> C Corporation <input type="checkbox"/> S Corporation <input type="checkbox"/> Partnership <input type="checkbox"/> Trust/estate <input type="checkbox"/> Limited liability company. Enter the tax classification (C=C corporation, S=S corporation, P=partnership) ▶ _____ <input type="checkbox"/> Other (see instructions) ▶ _____	
	Exemptions (see instructions): Exempt payee code (if any) _____ Exemption from FATCA reporting code (if any) _____	
	Address (number, street, and apt. or suite no.) 524 SPRINGFIELD DRIVE AND 15876 SCHAEFER HWY	Requester's name and address (optional) CITY OF NOVI CITY CLERK'S OFFICE NOVI, MI 48375-3024
City, state, and ZIP code CANTON, MICHIGAN 48188 DETROIT, MICHIGAN 48227		
List account number(s) here (optional)		

Part I Taxpayer Identification Number (TIN)

Enter your TIN in the appropriate box. The TIN provided must match the name given on the "Name" line to avoid backup withholding. For individuals, this is your social security number (SSN). However, for a resident alien, sole proprietor, or disregarded entity, see the Part I instructions on page 3. For other entities, it is your employer identification number (EIN). If you do not have a number, see *How to get a TIN* on page 3.

Note. If the account is in more than one name, see the chart on page 4 for guidelines on whose number to enter.

Social security number									
			-				-		

Employer identification number										
2	6		-	0	3	9	7	2	7	1

Part II Certification

Under penalties of perjury, I certify that:

- The number shown on this form is my correct taxpayer identification number (or I am waiting for a number to be issued to me), and
- I am not subject to backup withholding because: (a) I am exempt from backup withholding, or (b) I have not been notified by the Internal Revenue Service (IRS) that I am subject to backup withholding as a result of a failure to report all interest or dividends, or (c) the IRS has notified me that I am no longer subject to backup withholding, and
- I am a U.S. citizen or other U.S. person (defined below), and
- The FATCA code(s) entered on this form (if any) indicating that I am exempt from FATCA reporting is correct.

Certification instructions. You must cross out item 2 above if you have been notified by the IRS that you are currently subject to backup withholding because you have failed to report all interest and dividends on your tax return. For real estate transactions, item 2 does not apply. For mortgage interest paid, acquisition or abandonment of secured property, cancellation of debt, contributions to an individual retirement arrangement (IRA), and generally, payments other than interest and dividends, you are not required to sign the certification, but you must provide your correct TIN. See the instructions on page 3.

Sign Here	Signature of U.S. person	Date ▶ 06-21-2016
------------------	--------------------------	-------------------

General Instructions

Section references are to the Internal Revenue Code unless otherwise noted.

Future developments. The IRS has created a page on IRS.gov for information about Form W-9, at www.irs.gov/w9. Information about any future developments affecting Form W-9 (such as legislation enacted after we release it) will be posted on that page.

Purpose of Form

A person who is required to file an information return with the IRS must obtain your correct taxpayer identification number (TIN) to report, for example, income paid to you, payments made to you in settlement of payment card and third party network transactions, real estate transactions, mortgage interest you paid, acquisition or abandonment of secured property, cancellation of debt, or contributions you made to an IRA.

Use Form W-9 only if you are a U.S. person (including a resident alien), to provide your correct TIN to the person requesting it (the requester) and, when applicable, to:

- Certify that the TIN you are giving is correct (or you are waiting for a number to be issued),
- Certify that you are not subject to backup withholding, or
- Claim exemption from backup withholding if you are a U.S. exempt payee. If applicable, you are also certifying that as a U.S. person, your allocable share of any partnership income from a U.S. trade or business is not subject to the withholding tax on foreign partners' share of effectively connected income, and

4. Certify that FATCA code(s) entered on this form (if any) indicating that you are exempt from the FATCA reporting, is correct.

Note. If you are a U.S. person and a requester gives you a form other than Form W-9 to request your TIN, you must use the requester's form if it is substantially similar to this Form W-9.

Definition of a U.S. person. For federal tax purposes, you are considered a U.S. person if you are:

- An individual who is a U.S. citizen or U.S. resident alien,
- A partnership, corporation, company, or association created or organized in the United States or under the laws of the United States,
- An estate (other than a foreign estate), or
- A domestic trust (as defined in Regulations section 301.7701-7).

Special rules for partnerships. Partnerships that conduct a trade or business in the United States are generally required to pay a withholding tax under section 1446 on any foreign partners' share of effectively connected taxable income from such business. Further, in certain cases where a Form W-9 has not been received, the rules under section 1446 require a partnership to presume that a partner is a foreign person, and pay the section 1446 withholding tax. Therefore, if you are a U.S. person that is a partner in a partnership conducting a trade or business in the United States, provide Form W-9 to the partnership to establish your U.S. status and avoid section 1446 withholding on your share of partnership income.

