



CITY of NOVI CITY COUNCIL

**Agenda Item H
June 27, 2016**

SUBJECT: Approval to award bid for 55 refrigerators at Meadowbrook Commons to Best Buy in the amount of \$24,475.

SUBMITTING DEPARTMENT: Parks, Recreation and Cultural Services

CITY MANAGER APPROVAL: 

EXPENDITURE REQUIRED	\$ 24,475
AMOUNT BUDGETED	\$ 35,000 (FY 2016-17 Budget)
APPROPRIATION REQUIRED	\$ -0-
LINE ITEM NUMBER	594-000.00-969.003

BACKGROUND INFORMATION: City Council approved the purchase of 55 refrigerators at Meadowbrook Commons in the FY 2016-17 budget to replace the original units purchased in 2001.

Three (3) bids were received and opened on June 14, 2016, following a public bid solicitation period. Staff is recommending the award to Best Buy, who was the lowest bidder. Best Buy met all of the requirements listed in the request for proposals.

A summary of the three bids are as follows:

Contractor	Bid Price
Best Buy	\$24,475
Sears/Ray Phillips	\$28,325
Business Services	\$32,449

The replacement of refrigerators is scheduled to begin in mid-summer and will be substantially complete by late August.

RECOMMENDED ACTION: Approval to award bid for 55 refrigerators at Meadowbrook Commons to Best Buy in the amount of \$24,475.

	1	2	Y	N
Mayor Gatt				
Mayor Pro Tem Staudt				
Council Member Burke				
Council Member Casey				

	1	2	Y	N
Council Member Markham				
Council Member Mutch				
Council Member Wrobel				



CITY OF NOVI

**REFRIGERATOR REPLACEMENTS –
MEADOWBROOK COMMONS**

BID FORM

We, the undersigned as bidder, propose to furnish to the City of Novi, according to the specifications, terms, conditions and instructions attached hereto and made a part thereof:

A. REFRIGERATORS, as specified

Unit Price (delivered & installed)		Quantity		Total Price (delivered & installed)
\$ 445.00	X	55	=	\$ 24,475.00

Make/Models Proposed (please include cut sheets/specifications for the refrigerators you will be providing)

Frigidaire Model FFTR1814QW - 18.0 CuFt Top Freezer

See attached data sheets for complete specifications

Lead Time (after receipt of order) 7-14 days

Days required to complete the work Best Buy will complete this work in 3-5 business days

We acknowledge receipt of the following Addenda: _____
(please indicate numbers)

We have included a completed W9 with our bid: Yes xxx No _____

Do you accept payment via Purchasing Card (credit card)? Best Buy will not accept payment of Net 30 accounts with a P Card, but will accept upfront payment using a P Card or credit card.

Please indicate service charges to use Purchasing card, if any: None

EXCEPTIONS TO SPECIFICATIONS (all exceptions must be noted here):

No exceptions

COMMENTS: _____

NON-IRAN LINKED BUSINESS

By signing below, I certify and agree on behalf of myself and the company submitting this proposal the following: (1) that I am duly authorized to legally bind the company submitting this proposal; and (2) that the company submitting this proposal is not an "Iran linked business," as that term is defined in Section 2(e) of the Iran Economic Sanctions Act, being Michigan Public Act No. 517 of 2012; and (3) That I and the company submitting this proposal will immediately comply with any further certifications or information submissions requested by the City in this regard.

THIS BID SUBMITTED BY:

Company (Legal Registration) Best Buy Stores, L.P. dba Best Buy For Business

Address 7601 Penn Ave South D-5

City Richfield State MN Zip 55423

Telephone 248-686-4113 Fax 952-430-9011

Representative's Name Jill Ranft

Representative's Title Sr. Contract Specialist

Authorized Signature 

E-mail Dan@bestbuy.com

Date 06/14/2016

FRIGIDAIRE

Top Mount Refrigerators

FFTR1814Q S/W/B

18 Cu. Ft. Top Mount



Product Dimensions

Height (Including Hinges & Rollers)	66-1/8"
Width	30"
Depth (Including Door)	29-7/8"

More Easy-To-Use Features

Independent Temperature Controls

Color-Coordinated Door Hinge Covers¹

Clear Dairy Door

Reversible Door

Door can be installed to open left or right based on your needs.

A.D.A. - Compliant²

With accessible shelving, and controls that are positioned within arm's reach and allow one-hand operation, our top-freezer refrigerator is A.D.A.-Compliant.

ADA

Available In:



Stainless
(S)



White
(W)



Black
(B)

¹Select models only.

²When properly installed, this model is A.D.A.-qualified based on the United States Access Board's A.D.A./A.B.A. Accessibility Guidelines and the Department of Justice's 2010 A.D.A. Standards for Accessible Design.

Signature Features

Built with American Pride

Appliances that are high-performing, more accessible, and more innovative than ever—designed, built, and engineered in the U.S.A.

Store-More™ Gallon Door Shelf

Door storage gives you room for larger items like a gallon of milk.

Store-More™ Humidity- Controlled Crisper Drawers

Our humidity-controlled crisper drawers are designed to keep your fruits and vegetables fresh so you don't have to worry about stocking up.

Full-Width Wire Freezer Rack

Enjoy more usable space and better organization.

Features	
Door Design	UltraSoft™
Door Handle Design	Black (S), Color-Coordinated (W/B)
Cabinet Finish (Textured)	Black (S), Color-Coordinated (W/B)
Door Stops	Yes
Door Hinge Covers	Black (S), Color-Coordinated (W/B)
Door Reverse Option	Yes
Rollers - Front/Rear	Fixed/Yes
Sound Package	
Toe Grille	Black (S), Color-Coordinated (W/B)
Garage-Ready	
Refrigerator Features	
Interior Lighting	Bright
Refrigerator Shelves	2 Full-Width SpaceWise® Wire
Deli Drawer	
Wine/Can Rack	
Store-More™ Crisper Drawers	2 Clear
Humidity Controls	2
Dairy Compartment	Clear Dairy Door
Door Bins	
Door Racks	3 Full-Width White
Non-Slip Bin Liner	
Tall Bottle Retainers	
Gallon Door Storage	1
Freezer Features	
Door Bins	
Door Racks	2 Full-Width White
Freezer Shelves	1 Full-Width Wire
Factory Ice Maker w/ Large Ice Bin	Optional (PN # IM116)
Lighting	
Certifications	
A.D.A. - Compliant ¹	Yes
Specifications	
Total Capacity (Cu. Ft.)	18.0
Refrigerator Capacity (Cu. Ft.)	14.1
Freezer Capacity (Cu. Ft.)	3.9
Power Supply Connection Location	Right Bottom Rear
Water Inlet Connection Location	Bottom Right
Voltage Rating	120V / 60Hz / 15A
Connected Load (kW Rating) @ 120 Volts ²	.72
Amps @ 120 Volts	6.0
Minimum Circuit Required (Amps)	15
Shipping Weight (Approx.)	205 Lbs.

¹When properly installed, this model is A.D.A.-qualified based on the United States Access Board's A.D.A./A.B.A. Accessibility Guidelines and the Department of Justice's 2010 A.D.A. Standards for Accessible Design.
²For use on adequately wired 120V, dedicated circuit having 2-wire service with a separate ground wire. Appliance must be grounded for safe operation.

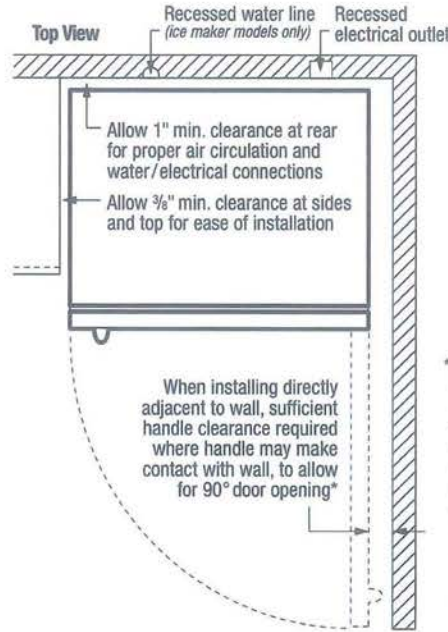
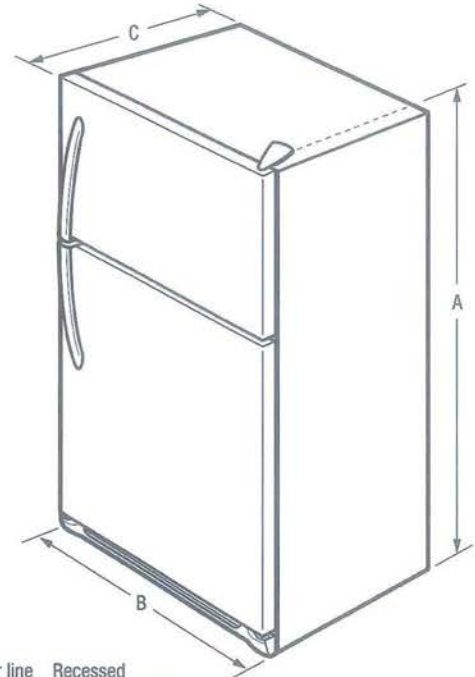

*When installing refrigerator adjacent to wall, cabinet or other appliance that extends beyond front edge of unit, 20" minimum clearance recommended to allow for optimum 140° door swing, providing complete crisper access and removal. (Absolute 3" minimum clearance will ONLY allow for 90° door swing which will provide limited crisper access with restricted removal.)

NOTE: For planning purposes only. Always consult local and national electric and plumbing codes. Refer to Product Installation Guide for detailed installation instructions on the web at frigidaire.com.



Product Dimensions	
A - Height (Incl. Hinges & Rollers)	66-1/8"
B - Width	30"
C - Depth (Incl. Door)	29-7/8"
Depth with Door Open 90°	58-1/2"

Accessories information available on the web at frigidaire.com

Specifications subject to change.

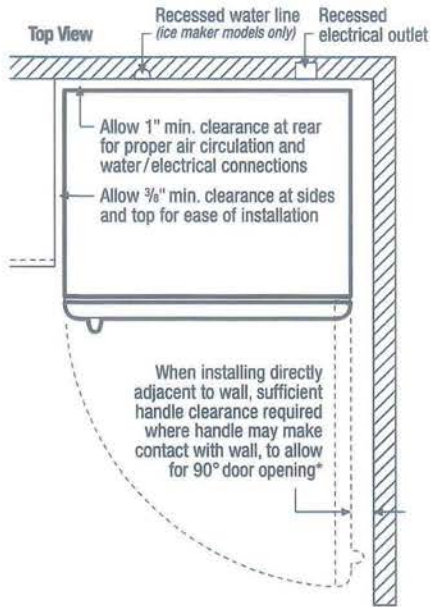

* When installing refrigerator adjacent to wall, cabinet or other appliance that extends beyond front edge of unit, 20" minimum clearance recommended to allow for optimum 140° door swing, providing complete crisper access and removal. (Absolute 3" minimum clearance will ONLY allow for 90° door swing which will provide limited crisper access with restricted removal.)

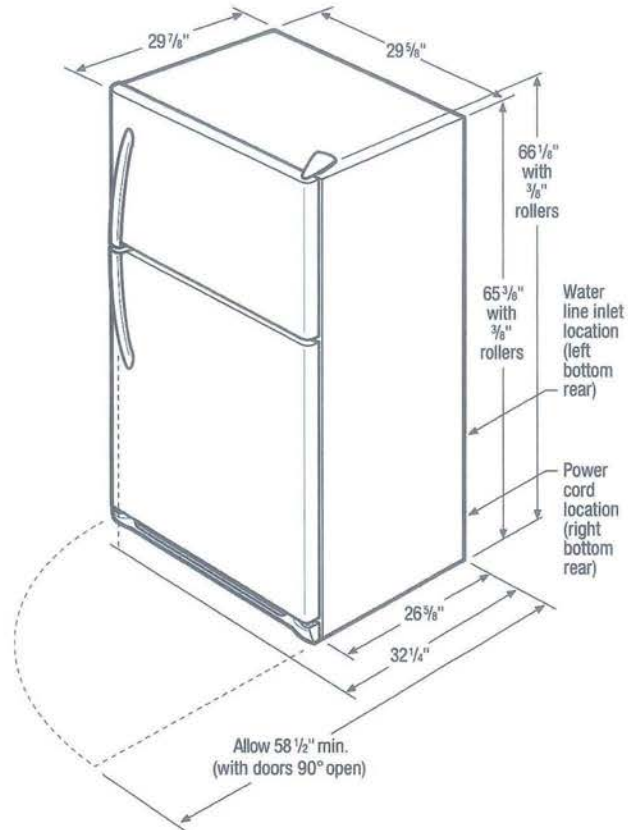

Top Mount Refrigerator Specifications

- Product Shipping Weight (approx.) - 205 Lbs.
- An electrical supply with grounded three-prong receptacle is required. The power supply circuit must be installed in accordance with current edition of National Electrical Code (NFPA 70) and local codes & ordinances.
- Voltage Rating - 120V / 60 Hz / 15 Amps
- Connected Load (kW Rating) @ 120 Volts = .72 kW
- Amps @ 120 Volts = 6.0 Amps
- Always consult local and national electric & plumbing codes.
- Floor should be level surface of hard material, capable of supporting fully loaded refrigerator.
- Minimum 3/8" clearance required for sides and top of refrigerator with 1" clearance at rear to allow for ease of installation, proper air circulation, and plumbing/electrical connections.
- When installing refrigerator adjacent to wall, cabinet or other appliance that extends beyond front edge of unit, 20" minimum clearance recommended to allow for optimum 140° door swing, providing complete crisper access and removal. (Absolute 3" minimum clearance will ONLY allow for 90° door swing which will provide limited crisper access with restricted removal.)

- To ensure optimum performance, do not install in areas where temperature drops below 55° F or rises above 110° F and avoid installing in direct sunlight or close proximity to range, dishwasher or other heat source.
- For proper ventilation, front grille MUST remain unobstructed.
- Recess electrical outlet when possible.
- Optional Ice Maker Kit (PN# IM116) available for installation in ice maker-ready models only.
- Water recess on rear wall recommended to prevent water line damage.
- Water Pressure - Cold water line must provide between 30 and 100 pounds per square inch (psi).
- Copper tubing with 1/4" O.D. recommended for water supply line with length equal to distance from rear of unit to household water supply line plus 7 additional feet. Optional Water Supply Installation Kits available.

Note: For planning purposes only. Refer to Product Installation Guide on the web at frigidaire.com for detailed instructions.

Optional Accessories

- Ice Maker Kit - (PN# IM116).



June 13, 2016

City of Novi
City Clerk's Office
45175 Ten Mile Road
Novi, MI 48375-3024

RE: Invitation to Bid Refrigerator Replacements - Meadowbrook Commons
DUE: Tuesday, June 14, 2016 2:00 PM

Thank you for taking the time to review our proposal to support the refrigerator replacements for Meadowbrook Commons. Based on the information contained in your document, Best Buy has assembled the attached proposal.

Please feel free to reach out to your primary contact, Sr. Strategic Account Executive Dan Wieczorek, whose information is below, with any questions or concerns you may have.

Dan Wieczorek
Sr. Strategic Account Executive
Direct: 248-686-4113
Fax: 952-430-3182
Dan@bestbuy.com

Best Buy looks forward to answering any additional questions you might have.

Thank you,

A handwritten signature in blue ink, appearing to read 'Jill'.

Jill Ranft
Sr. Contract Specialist BBFB
Office: 612-291-7076
Mobile: 612-701-8182
Jill.Ranft@bestbuy.com



FOR BUSINESS

As part of the decision process, you should know a little bit about Best Buy for Business (BBFB). Best Buy for Business is the Commercial division of Best Buy Company (NYSE:BBY). BBFB sells to business, education and government customers through our network of dedicated sellers.

Best Buy Company Inc. is a Fortune 100 company incorporated in Minnesota. Approximately 125,000 employees apply their talents to help bring the benefits of these brands to life for customers through retail locations, multiple call centers and web sites, Geek Squad Precincts, in-home solutions, product delivery and in our communities. With operations in the United States, Mexico and Canada, Best Buy Co., Inc. is a multinational retailer of:

- Commercial and consumer grade computers and information technology hardware, software and peripherals
- Commercial and consumer grade audio-visual hardware and peripherals
- Commercial and household appliances
- Geek Squad services and third party installation services

The Best Buy Co., Inc. family of brands and partnerships collectively generates more than \$40 billion annual revenue and includes brands such as Best Buy, Best Buy for Business, Audiovisions, Geek Squad, Jiangu Five Star, Magnolia Audio Video, and Pacific Sales Kitchen and Bath Centers.

To complete the Best Buy picture, we bring in our retail location partners. With more than 1400 retail locations nationwide and Geek Squad in most retail locations, not to mention our BBFB sales force nationwide, we are close to our customers and our support goes beyond just a mailing address. When a BBFB product is sold, there is a local Best Buy store and a dedicated team to support it.

BBFB's goal is to satisfy every one of our customers with the same level of support and aftercare as every customer that walks into our stores, which in many cases, is already one of our current customers. Your Account Manager is just a phone call or email away. With resources like this, we can provide high levels of service to meet your needs.

Best Buy is headquartered in Richfield, MN, a suburb of Minneapolis. Here 4000 employees, including those at Best Buy For Business, provide services to our divisions and customers. Our office is at:

Best Buy For Business
7601 Penn Ave South D-5
Richfield, MN 55423

Our BBFB Sales Team, of which Dan Wiezcorek is a member, serves our customer base. And we include our retail partners as part of our local presence. As you can see above, we truly partner with our retail and Geek Squads to bring the highest level of service to each of our customers.

Best Buy for Business has close relationships with our vendor partners. Our Account Managers are in training weekly to continue to build their knowledge of our extensive catalog of products. Best Buy for



FOR BUSINESS

Business sees our customer relationships as a continually changing and growing effort from both parties. Best Buy for Business will continue to improve efficiencies as our relationship grows so that we may create a mutually beneficial relationship.

BBFB is keenly aware that flexibility and variety are important to our customers which is why we are happy offer you a range of payment and financing options. We are set up to take Wire Transfers, Checks or Credit Cards. We offer in-house financing options of Net 30 and Net 45 and can even provide you with product financing options from 6 months up to 3 years.

Thank you for taking the time to review our proposal. The BBFB sales and support teams are here to answer any questions you may have about anything contained as part of this bid. We look forward to hearing from you.

Request for Taxpayer Identification Number and Certification

**Give Form to the
requester. Do not
send to the IRS.**

Print or type See Specific Instructions on page 2.	1 Name (as shown on your income tax return). Name is required on this line; do not leave this line blank. Best Buy Stores, L.P.		
	2 Business name/disregarded entity name, if different from above Best Buy For Business		
	3 Check appropriate box for federal tax classification; check only one of the following seven boxes: <input type="checkbox"/> Individual/sole proprietor or single-member LLC <input checked="" type="checkbox"/> C Corporation <input type="checkbox"/> S Corporation <input type="checkbox"/> Partnership <input type="checkbox"/> Trust/estate <input type="checkbox"/> Limited liability company. Enter the tax classification (C=C corporation, S=S corporation, P=partnership) ▶ _____ <small>Note. For a single-member LLC that is disregarded, do not check LLC; check the appropriate box in the line above for the tax classification of the single-member owner.</small> <input type="checkbox"/> Other (see instructions) ▶ _____		4 Exemptions (codes apply only to certain entities, not individuals; see instructions on page 3): Exempt payee code (if any) <u>5</u> Exemption from FATCA reporting code (if any) <u>E</u> <small>(Applies to accounts maintained outside the U.S.)</small>
	5 Address (number, street, and apt. or suite no.) 7601 Penn Avenue South		Requester's name and address (optional)
	6 City, state, and ZIP code Richfield, MN 55423		
	7 List account number(s) here (optional)		

Part I Taxpayer Identification Number (TIN)

Enter your TIN in the appropriate box. The TIN provided must match the name given on line 1 to avoid backup withholding. For individuals, this is generally your social security number (SSN). However, for a resident alien, sole proprietor, or disregarded entity, see the Part I instructions on page 3. For other entities, it is your employer identification number (EIN). If you do not have a number, see *How to get a TIN* on page 3.

Note. If the account is in more than one name, see the instructions for line 1 and the chart on page 4 for guidelines on whose number to enter.

Social security number	
[] [] [] - [] [] - [] [] [] []	
OR	
Employer identification number	
4 1 - 1 8 2 2 8 7 2	

Part II Certification

Under penalties of perjury, I certify that:

- The number shown on this form is my correct taxpayer identification number (or I am waiting for a number to be issued to me); and
- I am not subject to backup withholding because: (a) I am exempt from backup withholding, or (b) I have not been notified by the Internal Revenue Service (IRS) that I am subject to backup withholding as a result of a failure to report all interest or dividends, or (c) the IRS has notified me that I am no longer subject to backup withholding; and
- I am a U.S. citizen or other U.S. person (defined below); and
- The FATCA code(s) entered on this form (if any) indicating that I am exempt from FATCA reporting is correct.

Certification instructions. You must cross out item 2 above if you have been notified by the IRS that you are currently subject to backup withholding because you have failed to report all interest and dividends on your tax return. For real estate transactions, item 2 does not apply. For mortgage interest paid, acquisition or abandonment of secured property, cancellation of debt, contributions to an individual retirement arrangement (IRA), and generally, payments other than interest and dividends, you are not required to sign the certification, but you must provide your correct TIN. See the instructions on page 3.

Sign Here Signature of U.S. person ▶ Laura J. Muzgenberger Date ▶ January 7, 2016

General Instructions

Section references are to the Internal Revenue Code unless otherwise noted.

Future developments. Information about developments affecting Form W-9 (such as legislation enacted after we release it) is at www.irs.gov/fw9.

Purpose of Form

An individual or entity (Form W-9 requester) who is required to file an information return with the IRS must obtain your correct taxpayer identification number (TIN) which may be your social security number (SSN), individual taxpayer identification number (ITIN), adoption taxpayer identification number (ATIN), or employer identification number (EIN), to report on an information return the amount paid to you, or other amount reportable on an information return. Examples of information returns include, but are not limited to, the following:

- Form 1099-INT (interest earned or paid)
- Form 1099-DIV (dividends, including those from stocks or mutual funds)
- Form 1099-MISC (various types of income, prizes, awards, or gross proceeds)
- Form 1099-B (stock or mutual fund sales and certain other transactions by brokers)
- Form 1099-S (proceeds from real estate transactions)
- Form 1099-K (merchant card and third party network transactions)

- Form 1098 (home mortgage interest), 1098-E (student loan interest), 1098-T (tuition)
- Form 1099-C (canceled debt)
- Form 1099-A (acquisition or abandonment of secured property)

Use Form W-9 only if you are a U.S. person (including a resident alien), to provide your correct TIN.

If you do not return Form W-9 to the requester with a TIN, you might be subject to backup withholding. See *What is backup withholding?* on page 2.

By signing the filled-out form, you:

- Certify that the TIN you are giving is correct (or you are waiting for a number to be issued),
- Certify that you are not subject to backup withholding, or
- Claim exemption from backup withholding if you are a U.S. exempt payee. If applicable, you are also certifying that as a U.S. person, your allocable share of any partnership income from a U.S. trade or business is not subject to the withholding tax on foreign partners' share of effectively connected income, and
- Certify that FATCA code(s) entered on this form (if any) indicating that you are exempt from the FATCA reporting, is correct. See *What is FATCA reporting?* on page 2 for further information.



**NOTICE - CITY OF NOVI
INVITATION TO BID**

**REFRIGERATOR REPLACEMENTS –
MEADOWBROOK COMMONS**

The City of Novi will receive sealed bids for **Refrigerator Replacements-Meadowbrook Commons** according to the specifications of the City of Novi.

Sealed bids will be received until **2:00 P.M.** prevailing Eastern Time, **Tuesday, June 14, 2016** at which time bids will be opened and read. Bids shall be addressed as follows and delivered to:

**CITY OF NOVI
CITY CLERK'S OFFICE**
45175 Ten Mile Rd.
Novi, MI 48375-3024

All bids must be signed by a legally authorized representative of the bidding firm. **OUTSIDE OF MAILING ENVELOPES/PACKAGES MUST BE PLAINLY MARKED "Refrigerator Replacements Bid" AND MUST BEAR THE NAME OF THE BIDDER.**

The City reserves the right to accept any or all alternative bids and award a contract to other than the lowest bidder, to waive any irregularities or informalities or both; to reject any or all bids; to subdivide the award, and in general to make the award of the contract in any manner deemed by the City, in its sole discretion, to be in the best interest of the City of Novi.

Sue Morianti
Purchasing Manager

Notice Dated: May 24, 2016

NOTICE TO BIDDERS:

The City of Novi officially distributes bid documents through the Michigan Intergovernmental Trade Network (MITN). **Copies of bid documents obtained from any other source are not considered official copies.** The City of Novi cannot guarantee the accuracy of any information not obtained from the MITN website and is not responsible for any errors contained by any information received from alternate sources. Only those vendors who obtain bid documents from the MITN system are guaranteed access to receive addendum information, if such information is issued. If you obtained this document from a source other than the source indicated, it is recommended that you register on the MITN site, www.mitn.info and obtain an official copy.



CITY OF NOVI
REFRIGERATOR REPLACEMENTS –
MEADOWBROOK COMMONS
INSTRUCTIONS TO BIDDERS

This bid is issued by the Purchasing Office of the City of Novi.

IMPORTANT DATES

Bid Issue Date	May 24, 2016
Last Date for Questions	Tuesday, June 7, 2016 by 12:00 P.M. Please submit all questions via email to: Sue Morianti, Purchasing Manager smorianti@cityofnovi.org
Response Due Date	Tuesday, June 14, 2016 by 2:00 P.M.
Anticipated award date	July 11, 2016

QUESTIONS

Please email all questions to the staff member listed above. Please write the name of the bid in the subject line. If you write anything else in the subject line, your email may be deleted as spam.

TYPE OF CONTRACT

If a contract is executed as a result of the bid, it stipulates a fixed price for products/ services.

BID SUBMITTALS

Provide **one (1) copy** of your bid, unbound, signed in ink, and clearly marked as ORIGINAL. Original bid may be clipped but should not be stapled or bound. No other distribution of the bids will be made by the Contractor. Bids must be signed by an official authorized to bind the Contractor to its provisions.

PLEASE SUBMIT A COMPLETED W9 WITH YOUR BID.

FAILURE TO SUBMIT PRICING ON THE BID FORM PROVIDED BY THE CITY OF NOVI MAY CAUSE THE BID TO BE CONSIDERED NON-RESPONSIVE AND INELIGIBLE FOR AWARD.

CHANGES TO THE BID/ADDENDA

Should any prospective Bidder be in doubt as to the true meaning of any portion of the ITB, or should the Bidder find any patent ambiguity, inconsistency, or omission therein, the Bidder shall make a written request (via email) for official interpretation or

correction. Such request shall be submitted to the staff member indicated above. The individual making the request shall be held responsible for its prompt delivery.

Such interpretation or correction, as well as any additional Bid provisions that the City may decide to include, will be made as an addendum, which will be posted on the MITN website at www.mitn.info . Any addendum issued by the City shall become part of the ITB and subsequent contract and shall be taken into account by each bidder in preparing its bid. Only written addenda is binding. It is the Bidder's responsibility to be sure they have obtained all addenda. Receipt of all addenda must be acknowledged on bid form.

SUBMISSION OF BID

Bids must be submitted in a sealed envelope, box, or package, and clearly marked with: ITB Title, Deadline, Respondent's name, address, phone, fax, and contact name. Failure to do so may result in a premature opening or failure to open such bid.

To be considered, sealed bids must arrive at City Clerk's Office on or before the specified time and date. There will be no exceptions to this requirement. Bid is considered received when in the possession of the City Clerk. The Clerk's Department time stamp will determine the official receipt time. Contractors mailing bids should allow ample time to ensure the timely delivery of their bid. Bids received after the closing date and time will not be accepted or considered. Faxed, emailed, or telephone bids are not acceptable. The City of Novi shall not be held responsible for lost or misdirected bids. The City reserves the right to postpone a bid opening for its own convenience.

All prices and notations must be typed or printed in ink. No erasures are permitted. Mistakes may be crossed out and corrections must be initialed in ink by the person signing the bid. Bids must be signed by an Authorized Representative of the submitting company on the enclosed form. Bids must show unit and total prices if requested. In case of mistakes in price extension, unit pricing shall govern.

A bid may be withdrawn by giving written notice to the Purchasing Manager before the stated due date/closing time. After the stated closing time, the bid may not be withdrawn or canceled for a period of One Hundred and Twenty (120) days from closing time.

Bidders are expected to examine all specifications and instructions. Failure to do so will be at the bidder's risk.

Failure to include in the bid all information requested may be cause for rejection of the bid.

Any samples, CDs, DVDs or any other items submitted with your bid will not be returned to the contractor.

No bid will be accepted from, or contract awarded to any person, firm, or corporation that is in arrears or is in default to the City of Novi upon any debt or contract, or that is in

default as surety or otherwise, or failed to perform faithfully any previous contract with the City.

USE OF THE CITY LOGO IN YOUR BID IS PROHIBITED.

CONSIDERATION OF BIDS

In cases where items are requested by a manufacturer's name, trade name, catalog number or reference, it is understood that the bidder/proposer intends to furnish the item so identified or an item of "equal" quality and value as determined by the City of Novi.

Reference to any of the above is intended to be descriptive, but not restrictive, and only indicates articles that will be satisfactory. Bids of "equal" quality and value will be considered, provided that the bidder states in his/her bid what he/she proposed to furnish, including literature, or other descriptive matter which will clearly indicate the character of the item covered by such bid.

The Purchasing Manager hereby reserves the right to approve as an "equal", any item proposed which contains minor or major variations from specification requirements, but which may comply substantially therewith.

RESPONSIVE BIDS

All pages and the information requested herein shall be furnished completely in compliance with instructions. The manner and format of submission is essential to permit prompt evaluation of all bids on a fair and uniform basis. Unit prices shall be submitted if space is provided on bid form. In cases of mistakes in extension, the unit price shall govern. Accordingly, the City reserves the right to declare as non-responsive, and reject an incomplete bid if material information requested is not furnished, or where indirect or incomplete answers or information is not provided. Any exceptions to the specifications must be noted on the bid form.

EXCEPTIONS

The City will not accept changes or exceptions to the bid documents/specifications unless Contractor indicates the change or exception in the "Exceptions" section of the bid form. If Contractor neglects to make the notation on the bid form but writes it somewhere else within the bid documents and is awarded the contract, the change or exception will not be included as part of the contract. The original terms, conditions and specifications of the bid documents will be applicable during the term of the contract.

CONTRACT AWARD

The contract will be awarded to that responsible, responsive bidder whose bid, conforming to this solicitation, will be most advantageous to the City of Novi. Qualifications, experience, references, comparable projects, price, previous experience with vendor/contractor, delivery, and other factors will be considered in the evaluation process and award of contract. The City reserves the right to accept any or all alternative bids and award the contract to other than the lowest bidder, to waive any irregularities or informalities or both; to reject any or all bids; and in general to make

the award of the contract in any manner deemed by the City, in its sole discretion, to be in the best interest of the City of Novi.

After contract award, a summary of total price information for all submissions will be posted on the MITN website at www.mitn.info.

The City may, from time to time, find it necessary to continue this contract on a month-to-month basis only, not to exceed a six (6) month period. Such month-to-month extended periods shall be by mutual agreement of both parties, with all provisions of the original contract or any extension thereof remaining in full force and effect.

VENDOR DISQUALIFICATION

The City maintains the right to disqualify vendors under the following conditions:

1. In addition to any other remedies authorized by law, a vendor may be disqualified from bidding on any City contracts for up to three (3) years if it has been determined that the vendor, after award of the contract:
 - (a) Failed to provide the service or supplies required;
 - (b) Provided the service or supplies in an untimely manner causing delays and interference;
 - (c) Lacked financial resources and the ability to satisfactorily perform the contract or provide the services or supplies;
 - (d) Exhibited poor quality of performance in delivering the service;
 - (e) Delivered poor quality of goods;
 - (f) Failed to comply with laws and ordinances relating to the contract performance;
 - (g) Defaulted on its quotations;
 - (h) Such other action what leads the City to believe that the contractor's duties will not comport or comply with the bid requirements.
2. Vendors who are listed on the Excluded Parties List System at www.sam.gov

GENERAL CONDITIONS

INSURANCE

A certificate of insurance naming the City of Novi as an additional insured must be provided by the successful bidder prior to commencement of work. A current certificate of insurance meeting the requirements in Attachment A is to be provided to the City and remain in force during the entire contract period.

CLEAN UP

The contractor shall keep the work area and surrounding area reasonable free from rubbish at all times and shall remove debris from the site from time to time or when directed to do so by the City's designated representative(s). Before final inspection and acceptance of the work, the Contractor shall clean his portion of the work area. All materials removed/replaced shall be the responsibility of the contractor to properly dispose of.

SAFETY REQUIREMENTS

The Contractor shall be solely responsible for the entire work site and provide all necessary protections as required by laws or ordinances governing such conditions and as required by the Owner. He shall be responsible for any damage to the Owner's property or that of others on the job, by himself, his personnel or his subcontractors, and shall make good such damages. He shall be responsible for and pay for any claims against the owner arising from such damages.

The Contractor shall provide all necessary safety measures for the protection of all persons on the work, and shall fully comply with all state laws or regulations and Michigan State building code requirements to prevent accident or injury to persons on or about the location of the work. He shall clearly mark or post signs warning of hazards existing, and shall barricade excavations and similar hazards. He shall protect against damage or injury resulting from falling materials and he shall maintain all necessary protective devices and signs throughout the progress of the work.

NO EXCLUSIVE CONTRACT

Contractor agrees and understands that the contract shall not be construed as an exclusive agreement and further agrees that the City may, at any time, secure similar or identical products/services at its sole option.

NOTICE TO BIDDERS

The City of Novi officially distributes bid documents through the Michigan Intergovernmental Trade Network (MITN). **Copies of bid documents obtained from any other source are not considered official copies.** The City of Novi cannot guarantee the accuracy of any information not obtained from the MITN website and is not responsible for any errors contained by any information received from alternate sources. Only those vendors who obtain bid documents from the MITN system are guaranteed access to receive addendum information, if such information is issued. If you obtained this document from a source other than the source indicated, it is recommended that you register on the MITN site, www.mitn.info and obtain an official copy.

TAX EXEMPT STATUS

It is understood that the City of Novi is a governmental unit, and as such, is exempt from the payment of all Michigan State Sales and Federal Excise taxes. Do not include such taxes in the bid prices. The City will furnish the successful bidder with tax exemption certificates when requested. The City's tax-exempt number is 38-6032551.

The following exception shall apply to installation projects: When sales tax is charged to the successful bidder for materials to be installed during the project, that cost shall be included in the "Complete for the sum of" bid price and not charged as a separate line item. The City is not tax exempt in this case and cannot issue an exemption certificate.

FREIGHT CHARGES/SHIPPING/HANDLING

All bid/proposal pricing is to be F.O.B. destination.

DOWN PAYMENTS OR PREPAYMENTS

Any bid submitted which requires a down payment or prepayment prior to delivery and full acceptance, as being in conformance with specifications, will not be considered for award. No payments will be made until work is performed/goods are received to the satisfaction of the authorized City representative.

INVOICING

Invoices must be mailed to: City of Novi, Attn: Finance Department, 45175 Ten Mile Road, Novi, MI 48375. We do not accept emailed or faxed invoices.

CONTRACT TERMINATION

The City may terminate and/or cancel this contract (or any part thereof) at any time during the term, any renewal, or any extension of this contract, upon thirty days (30) days written notice to the Contractor, for any reason, including convenience without incurring obligation or penalty of any kind. The effective date for termination or cancellation shall be clearly stated in the written notice.

TRANSFER OF CONTRACT/SUBCONTRACTING

The successful bidder will be prohibited from assigning, transferring, converting or otherwise disposing of the contract agreement to any other person, company or corporation without the expressed written consent of the City of Novi. Any subcontractor, so approved, shall be bound by the terms and conditions of the contract. The contractor shall be fully liable for all acts and omissions of its subcontractor(s) and shall indemnify the City of Novi for such acts or omissions.

NON-DISCRIMINATION

In the hiring of employees for the performance of work described in this ITB and subsequent contract, neither the contractor, subcontractor, nor any person acting in their behalf shall by reason of religion, race, color, national origin, age, sex, height, weight, handicap, ancestry, place of birth, sexual preference or marital status discriminate against any person qualified to perform the work required in the execution of the contract.

ACCEPTANCE OF BID CONTENT

Should a contract ensue, the contents of the bid of the successful Bidder may become contractual obligations. Failure of a contractor to accept these obligations may result in cancellation of the award.

DISCLOSURE

All documents, specifications, and correspondence submitted to the City of Novi become the property of the City of Novi and are subject to disclosure under the provisions of Public Act No. 442 of 1976 known as the "Freedom of Information Act". This Act also provides for the complete disclosure of contracts and attachments hereto. This means that any informational material submitted as part of this ITB is available without redaction to any individual or organization upon request.

ECONOMY OF PREPARATION

Bids should be prepared simply and economically, providing a straightforward and concise description of the bidder's ability to meet the requirements of the bid. Emphasis should be on completeness and clarity of content. Included in the response must be a point by point response to the Requirements and other sections of the bid.

The City of Novi is not liable for any costs incurred by bidders prior to issuance of a contract.

INDEPENDENT PRICE DETERMINATION

By submission of a bid, the offerer certifies, and in case of a joint bid, each party hereto certifies as to its own organization, that in connection with the bid:

- (a) The prices in the bid have been arrived at independently without consultation, communication, or agreement, for the purpose of restricting competition, as to any matter relating to such prices with any other offerer or with any other Competitor; and
- (b) No attempt has been made or will be made by the offerer to induce any other person or firm to submit or not submit a bid for the purpose of restricting competition.

Each person signing the bid certifies that:

- (c) He is the person in the offerer's organization responsible within that organization for the decision as to prices being offered in the bid and that he has not participated and will not participate in any action contrary to (a) and (b) above; or
- (d) He is not the person in the offerer's organization responsible within that organization for the decision as to prices being offered in the bid but that he has been authorized in writing to act as agent for the persons responsible for such decisions in verifying that such persons have not participated, and will not participate, in any action contrary to (a) and (b) above, and that as their agent, does hereby so certify; and that he has not participated, and will not participate in any action contrary to (a) and (b) above.

A bid will not be considered for award if the sense of the statements required in the bid has been altered so as to delete or modify the above.



CITY OF NOVI
REFRIGERATOR REPLACEMENTS -
MEADOWBROOK COMMONS

SPECIFICATIONS

OVERVIEW

The City of Novi owns and operates Meadowbrook Commons, a Senior Adult Housing Development located at 25075 Meadowbrook, Novi, Michigan 48375, containing sixty (60) ranch units (10 buildings), and a three-story apartment building with one- and two bedroom units. This project involves replacement of 55 refrigerators in the ranch unit apartments.

SCOPE OF WORK

- Uninstall existing refrigerators (55)
- Remove and/or dispose of old refrigerators and dispose of Freon in approved manner.
- Deliver and install new refrigerators (22 left swing, 23 right swing)
- Vendor to supply all necessary equipment/supplies, labor, and supervision.

PREFERRED REFRIGERATOR MODEL

Frigidaire H515407 (Mfg# FFTW1621QW)
White
No automatic icemaker



**CITY OF NOVI
INSURANCE REQUIREMENTS
ATTACHMENT A**

1. The Contractor shall maintain at its expense during the term of this Contract, the following insurance:
 - a. **Worker's Compensation** insurance with the Michigan statutory limits and Employer's Liability insurance with minimum limits of **\$100,000** (One Hundred Thousand Dollars) each accident.
 - b. **Commercial General Liability Insurance** – The Contractor shall procure and maintain during the life of this contract, Commercial General Liability Insurance, Personal Injury, Bodily Injury and Property Damage on an "Occurrence Basis" with limits of liability not less than **\$1,000,000** (One Million Dollars) per occurrence combined single limit.
 - c. **Automobile Liability** insurance covering all owned, hired and non-owned vehicles with Personal Protection insurance to comply with the provisions of the Michigan No Fault Insurance Law including Residual Liability insurance with minimum bodily injury limits of **\$1,000,000** (One Million Dollars) each person and **\$1,000,000** (One Million Dollars) each occurrence and minimum property damage limits of **\$1,000,000** (One Million Dollars) each occurrence.
2. All policies shall name the Contractor as the insured and shall be accompanied by a commitment from the insurer that such policies shall not be canceled or reduced without at least thirty (30) days prior notice date to the City; alternately, contractor may agree to provide notice of such cancellation or reduction.
3. The City of Novi shall be named as Additional Insured for General Liability and Auto Liability. Certificates of Insurance evidencing such coverage shall be submitted to City of Novi, Purchasing Department, 45175 Ten Mile Road, Novi, Michigan 48375-3024 prior to commencement of performance under this Contract and at least fifteen (15) days prior to the expiration dates of expiring policies. A current certificate of insurance must be on file with the City for the duration of the contract. Said coverage shall be PRIMARY COVERAGE rather than any policies and insurance self-insurance retention owned or maintained by the City. Policies shall be issued by insurers who endorse the policies to reflect that, in the event of payment of any loss or damages, subrogation rights under those contract documents will be waived by the insurer with respect to claims against the City
4. The Contractor shall be responsible for payment of all deductibles contained in any insurance required hereunder.

5. If, during the term of this Contract, changed conditions or other pertinent factors should in the reasonable judgment of the City render inadequate insurance limits, the Contractor will furnish on demand such additional coverage as may reasonably be required under the circumstances. All such insurance shall be effected at the Contractor's expense, under valid and enforceable policies, issued by the insurers of recognized responsibility which are well-rated by national rating organizations and are acceptable to the City.
6. If any work is sublet in connection with this Contract, the Contractor shall require each subcontractor to effect and maintain at least the same types and limits of insurance as fixed for the Contractor.
7. The provisions requiring the Contractor to carry said insurance shall not be construed in any manner as waiving or restricting the liability of the Contractor under this contract.
8. The City has the authority to vary from the specified limits as deemed necessary.

ADDITIONAL REQUIREMENTS

HOLD HARMLESS/INDEMNITY

1. The Contractor agrees to fully defend, indemnify and hold harmless the City, its City Council, its officers, employees, agents, volunteers and contractors from any claims, demands, losses, obligations, costs, expenses, verdicts, and settlements (including but not limited to attorney fees and interest) resulting from:
 - A. Acts or omissions by the Contractor, its agents, employees, servants and contractors in furtherance of execution of this Agreement, unless resulting from the sole negligence and tort of the City, its officers, employees, agents and contractors.
 - B. Violations of state or federal law involving whether administrative or judicial, arising from the nature and extent of this Agreement.
 - C. The Contractor agrees to defend the City from and against any and all actions or causes of action, claims, demands or whatsoever kind or nature arising from the operations of the Contractor and due to the acts or omissions of the Contractor or its agents, including, but not limited to, acts of omissions alleged to be in the nature of gross negligence or willful misconduct. The Contractor agrees to reimburse the City for reasonable attorney fees and court costs incurred in the defense of any actions, suits, claims or demands arising from the operations of the Contractor under this Agreement due to the above-referenced acts or omissions.

2. The Contractor agrees that it is its responsibility and not the responsibility of the City of safeguard the property and materials used in performing this Contract. Further the Contractor agrees to hold the City harmless for any loss of such property and materials used in pursuant to the Contractor's performance under this Contract.

3. The Contractor shall not discriminate against any employee, or applicant for employment because of religion, race, color, national origin, age, sex, height, weight, handicap, ancestry, place of birth, sexual preference or marital status. The Contractor further covenants that it will comply with the Civil Rights Act of 1973, as amended; and the Michigan Civil Rights Act of 1976 (78. Stat. 252 and 1976 PA 453) and will require a similar covenant on the part of any consultant or subcontractor employed in the performance of this contract.

CITY OF NOVI
Refrigerator Replacements - Meadowbrook Commons
June 14, 2016 2:00 P.M.

Company	Best Buy	Sears / Ray Phillips	Business Services
Unit price (delivered)	\$ 445.00	\$ 515.00	\$ 589.98
Quantity	55	55	55
TOTAL PRICE (DELIVERED)	\$ 24,475.00	\$ 28,325.00	\$ 32,448.90
Make/Model	Frigidaire Model FFTR1814QW	Kenmore 04660402000	Frigidaire FFTR1621RW
Lead Time (ARO)	7-14 days	3 weeks	10-14 ARO
Days require to complete the work	3-5 business days	1 week	1-2 days
Addenda acknowledged	N/A	N/A	N/A
Accepts payment via P-Card	Yes, if pay up front	yes	No
Service charges to use P-card	No	0	N/A
Comments			

ABC Warehouse - late bid