

136.75" X 51" = 6974.25" - : - 144" = 4843 SQ. FT.

EXISTING SIGN  
 (NOT ALLOWED BY CODE)

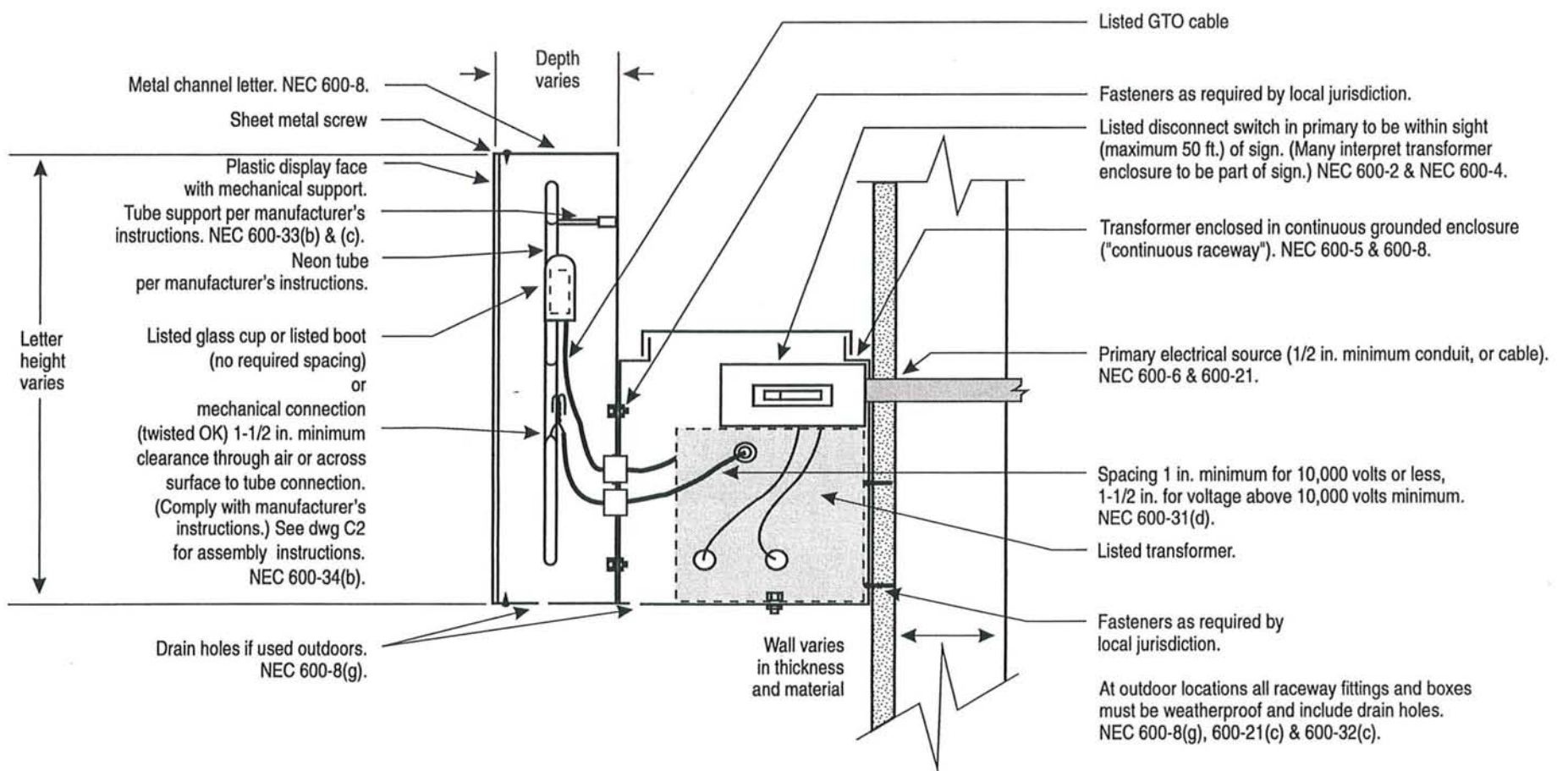

Manufacturer's Name  
Address

DATE: \_\_\_\_\_

VOLTAGE: \_\_\_\_\_

AMPERES: \_\_\_\_\_

No. LAMPS: \_\_\_\_\_

Markings per NEC 600-7

All rights reserved. No part of this work covered by the copyright hereon may be reproduced or used in any form or by any means - graphic, electronic, or mechanical, including photocopying, recording, taping, or information storage and retrieval systems - without written permission of the publisher, except that single copies of individual pages may be made by a bona fide electrical sign installation firm for the sole purpose of providing guidance on the installation of electrical signs or outline lighting, without the permission of the publisher.

Installation of nonlisted signs  
(As per NEC Section 600-4)

<b>ILLUMINATED INDOOR OR OUTDOOR METAL CHANNEL LETTER WITH CONTINUOUS ENCLOSURE ("RACEWAY")</b>	
	Date: October 1994
Scale None	IAEI Dwg. No. <b>NEC-T2</b>



96.25" X 36" = 3465" - 144" = 24.06 SQ. FT.

SIZE THAT IS ALLOWED BY CODE

June 22, 2009

GT Management  
200 Renaissance Center  
Suite 3145  
Detroit, MI 48243

To: City of Novi  
Zoning Board of Appeals

This letter is to support the request for a sign variance for our tenant, Tradewinds Spas. Due to the current difficult economic conditions, we have negotiated with them to move from City Center Plaza, Suite 130 to a smaller unit in the same plaza, Suite 124. Tradewinds Spas has been a good tenant for over 2 years. The sign in question was properly permitted and installed when they moved to Suite 130. The new smaller suite apparently places the existing wall sign out of basic code requirements. The size difference does not, we feel, look out of place or cause a problem within the plaza.

Again, we support this request for a variance because of the unique economic circumstances and hardships our retailers are experiencing.

Sincerely,

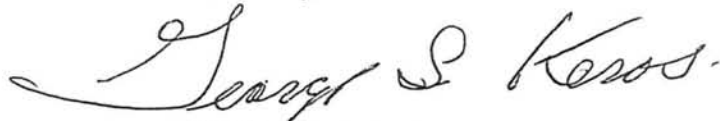
A handwritten signature in black ink that reads "George S. Keros". The signature is written in a cursive style with a long, sweeping underline.

GT Management  
George S. Keros, Landlord  
(313) 259-6720 (313) 259-6720